

Motor Starting Comparison Case # 2

Comparison of ETAP Motor Starting Results Against Transient Stability

Excerpts from Validation Cases and Comparison Results (TCS-MS-083)

Highlights

- Comparison of ETAP Motor acceleration results against Transient Stability results that have been validated against field measured data and hand calculations.
- Motor is rated at 200 HP at 0.46 kV. RPM = 1800. %PF = 91.71 and %Eff = 92.75.
- Motor CKT model is a Single (Single-cage with deep bars).
- The mechanical load model (Torque) is represented by the following polynomial equation $T = 100 * \omega$ (constant slope ramping load).
- The compared results include the motor current, motor real and reactive power demand and the motor slip. Please note that the Motor Starting study is able to predict the acceleration time very accurately.
- Refer to cases 1 to 5 published in http://www.etap.com/qa_tsvvcasedocs.htm for some TS validation results.

System Description

This is 3-Phase system that consists of three induction motors. One of the induction motors at the 0.480 kV bus is being started at $t = 0$ sec. The CKT model parameters are as shown on the Model page. The motor being started is 50St100Ld-1.

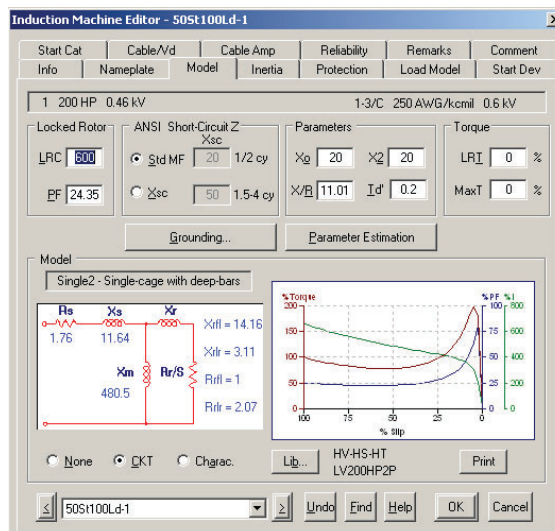
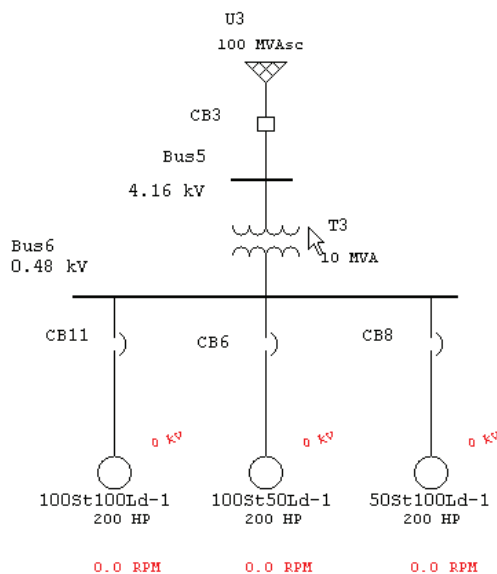

Comparison of Results

The following plots show the similarity between motor acceleration results obtained using ETAP Motor Starting and those obtained using ETAP Transient Stability. The TS model has been validated against hand calculations and field measured results as shown in the TS Verification & Validation Test Cases published on the ETAP Web site.

The compared plots are the Motor Current (Amps), Motor Electrical Power Demand (MW), Motor Reactive Power Demand (Mvar) and the Motor Slip (%).

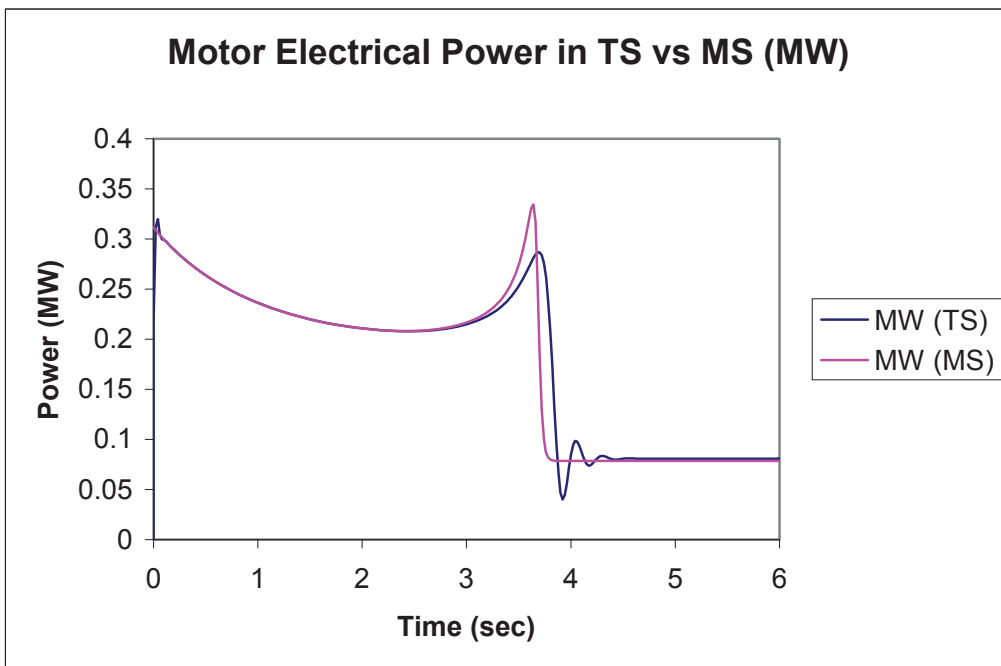
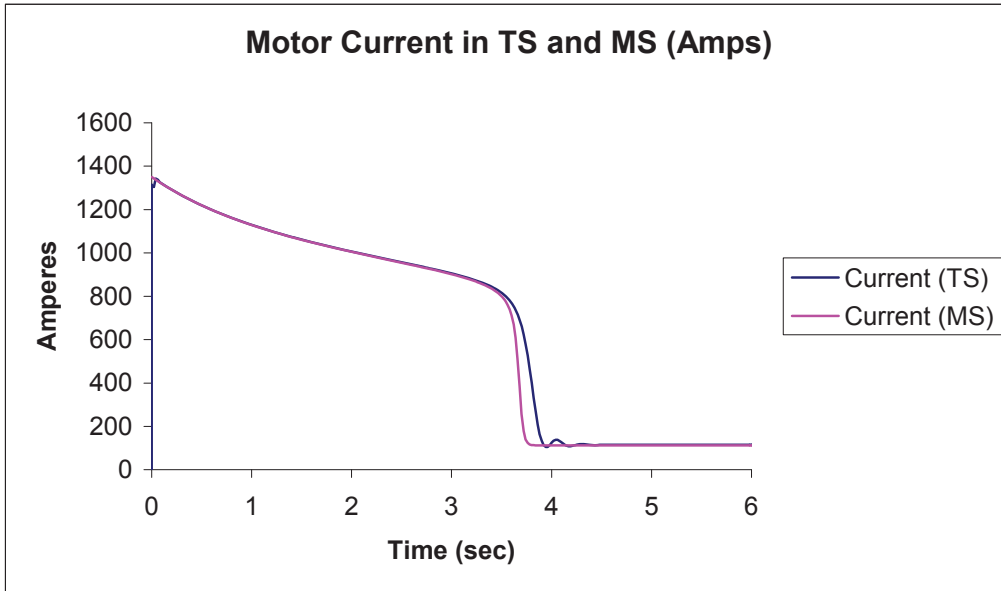

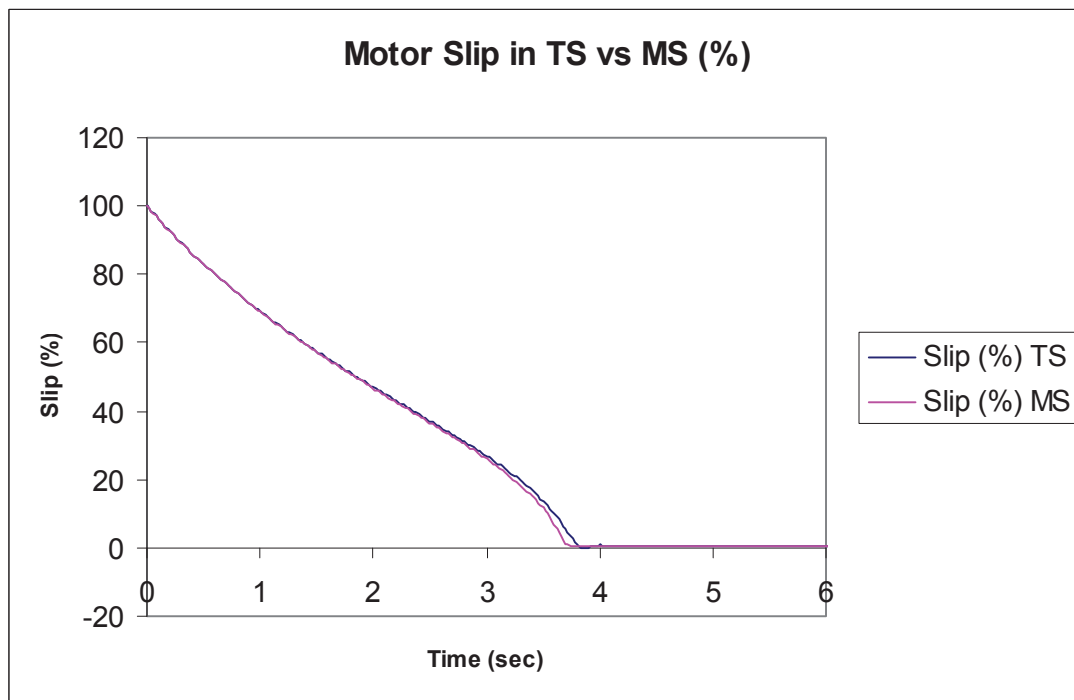
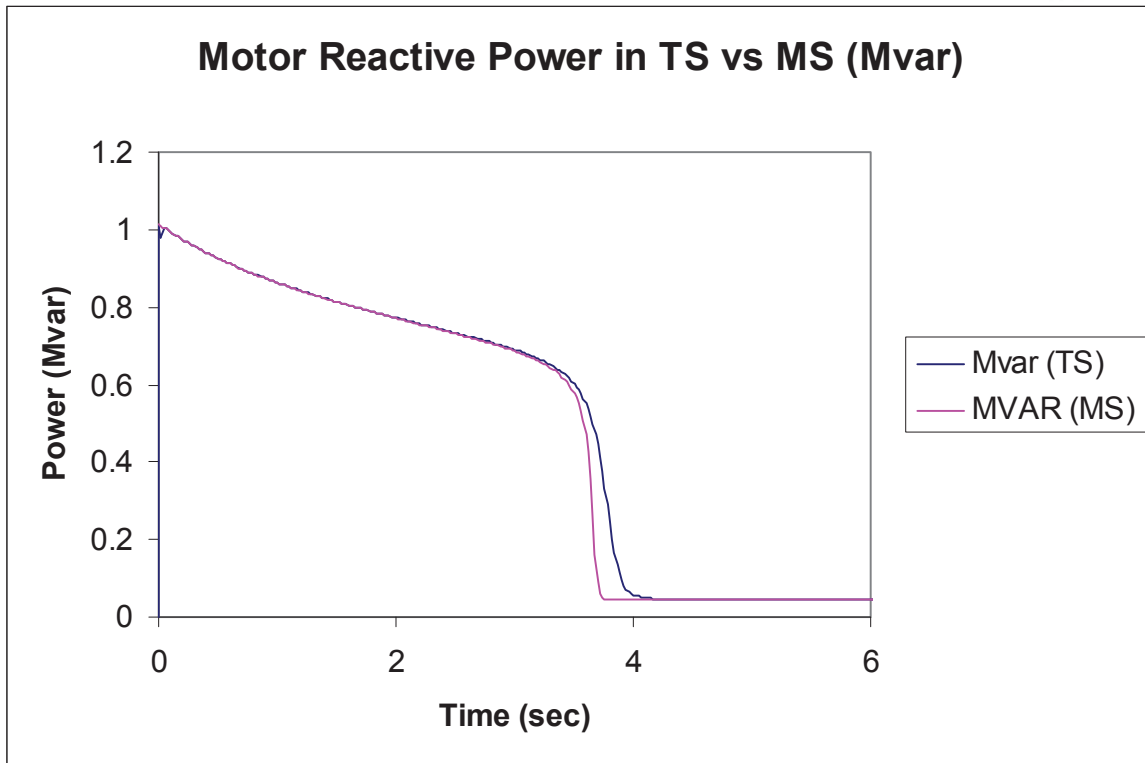

Reference

1. ETAP Motor Starting V&V Documents, Case Number TCS-MS-083.